

DENALI™

HMT.07.10300

COMPACT HORN MOUNT

BMW

R1200RT 2014 - 2016

Thank you for choosing DENALI

We know you would rather be riding your bike than wrenching on it, so we go the extra mile to make sure our instructions are clear and as easy to understand as possible. If you have any questions, comments, or suggestions don't hesitate to give our gear experts a call at 855.255.5550 or visit DenaliElectronics.com/instructions.

Please Read Before Installing

DENALI products should always be installed by a qualified motorcycle technician. If you are unsure of your ability to properly install a product, please have the product installed by your local motorcycle dealer. DENALI takes no responsibility for damages caused by improper installation. **Caution:** When installing electronics is it extremely important to pay close attention to how wires are routed, especially when mounting products to the front fender, front forks, or fairing of your motorcycle. Always be sure to turn the handlebars fully left, fully right, and fully compress the suspension to ensure the wires will not bind and have enough slack for your motorcycle to operate properly.

Installation Tips

We strongly recommend using medium strength liquid thread locker on all screws, nuts, and bolts. It is also important to ensure that all hardware is tightened to the proper torque specifications as listed in your owner's manual. For included accessory hardware please refer to the default torque specifications provided below. Inspect all hardware after the first 30 miles to ensure proper torque specifications are maintained.

Bolt Size	in-lbs	ft-lbs	Nm
M3	10.0 in-lbs	-	1.0 Nm
M4	23.0 in-lbs	-	2.5 Nm
M5	44.5 in-lbs	3.5 ft-lbs	5.0 Nm
M6	78.0 in-lbs	6.5 ft-lbs	9.0 Nm
M8	-	13.5 ft-lbs	18.0 Nm
M10	-	30.0 ft-lbs	41.0 Nm
M12	-	52.0 ft-lbs	71.0 Nm

Hardware Sizing Guide

Not sure what size bolt you have? Use this ruler to measure screws, bolts, spacers, etc. Remember, the length of a screw or bolt is measured from the start of the "mounting surface" to the end of the screw, so only include the screw head when measuring countersunk screws.

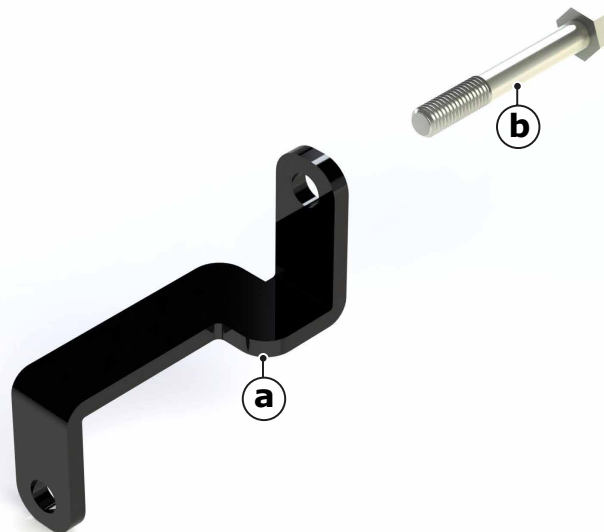
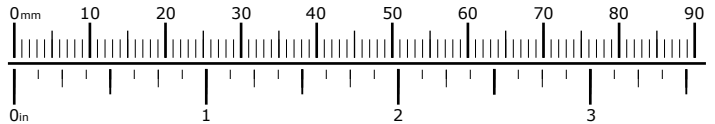

Kit Contents

- (a) Mounting Bracket.....Qty 1
- (b) M8x60 DIN 931.....Qty 1

Tools Required

- 13mm Wrench

FIGURE 2

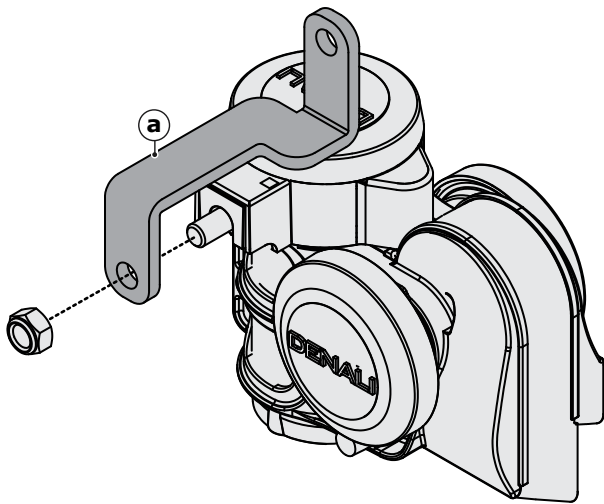

Attaching The Bracket

Step One: Use the hardware included with the horn to attach the mounting bracket (a) to the horn.

FIGURE 3

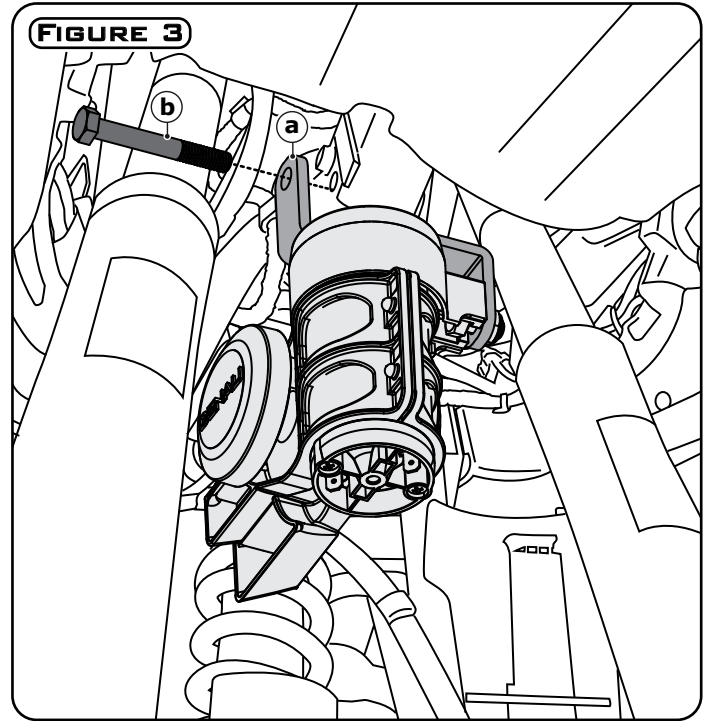

Installing The Horn

Step Two: Remove the lower OEM bolt from the fairing stay.

Step Three: Use the M8x60 bolt (b) to attach the bracket (a) and horn to the fairing stay. Do not fully tighten at this time.

Step Four: Rotate the handle bars fully left and right while making adjustments to the position of the bracket to insure the horn has no interference with either of the fork legs.

Step Five: Once final adjustments have been made, you may fully tighten the bolt.

Step Six: Before operating the motorcycle, turn the handlebars fully left, fully right, and fully compress the suspension. Confirm that the horn does not interfere with operation and that the wires have enough slack to account for all suspension and steering movement.