

BMW R 1200 RT (ab Baujahr 2014)
Motorschutzbügel

powered by

Nr.: 502.609 00 01 schwarz

Nr.: 502.609 00 02 chrom

Nr.: 502.609 00 09 silber

Der Bausatz umfasst die folgenden Teile:

Stück	Bestellnr.	Bezeichnung	Stück	Bestellnr.	Bezeichnung
1	700008441	Motorschutzbügel links schwarz	2	150.783	Inbusschrauben M8x20 DAC
1	700008442	Motorschutzbügel rechts schwarz	2	150.784	Inbusschrauben M8x25 DAC
oder			1	150.870	Inbusschrauben M10x55 DAC
1	700008443	Motorschutzbügel links chrom	8	150.810	U-Scheiben Ø8,4
1	700008444	Motorschutzbügel rechts chrom	1	150.811	U-Scheibe Ø 10,5
oder			2	150.800	selbstsichernde Muttern M8
1	700008438	Motorschutzbügel links silber	1	151.217	Aludistanzen ø18xø11x13mm
1	700008439	Motorschutzbügel rechts silber			





BMW R 1200 RT (ab Baujahr 2014)
Motorschutzbügel

powered by

Nr.: 502.609 00 01 schwarz

Nr.: 502.609 00 02 chrom

Nr.: 502.609 00 09 silber

LINKE SEITE

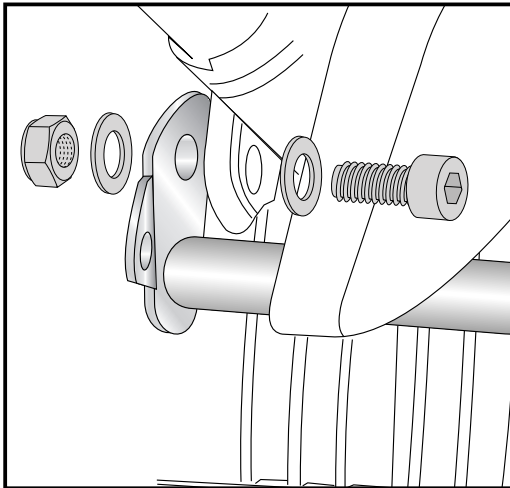

1

Info: Die Montage der Motorschutzbügel sollte seitenweise erfolgen!

Vorbereitende Maßnahmen:

Untere Kunststoffverkleidung um den Zylinder links und rechts demontieren.

Befestigung des Motorschutzbügels oben:

Den Motorschutzbügel so anhalten, dass die obere Befestigungslasche hinter (nach innen gerichtet) der Motorradrahmenlasche anliegt.

Die obere Befestigungslasche mit der Inbusschraube M8x25, den U-Scheiben $\varnothing 8,4$ und einer selbstsichernden Mutter M8 befestigen.

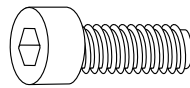

1x

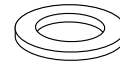

2x

1x



Befestigung des Motorschutzbügels

vorne unten :

mit einer Inbusschraube M8x20 und einer U-Scheibe $\varnothing 8,4$. Zwischen dem Motorblock und der Befestigungslasche eine U-Scheibe $\varnothing 8,4$ einfügen.

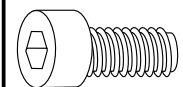

1x

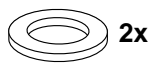

2x

2

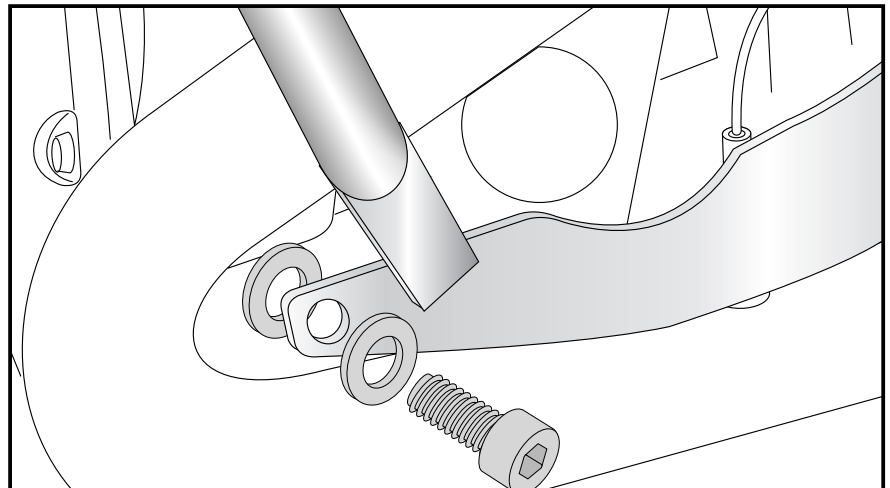

Fahrtrichtung

Befestigung des Motorschutzbügels

hinten unten:

mit der Originalschraube.

3

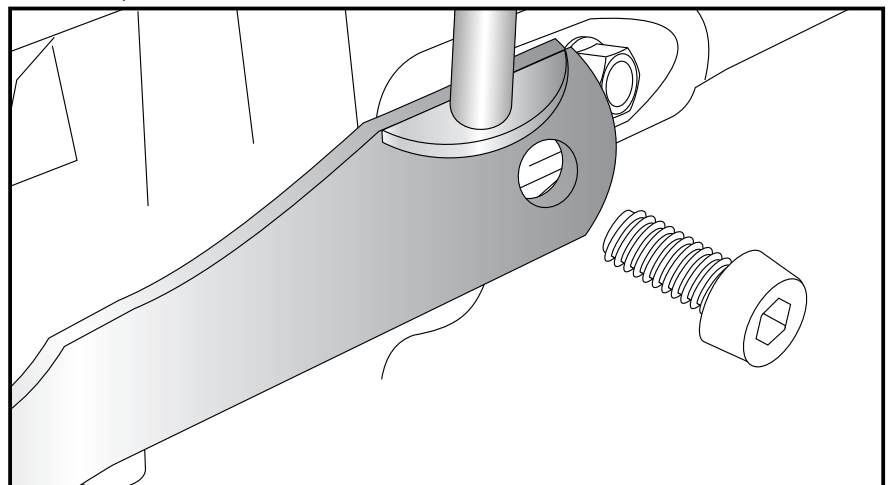

BMW R 1200 RT (ab Baujahr 2014)
Motorschutzbügel

Nr.: 502.609 00 01 schwarz

Nr.: 502.609 00 02 chrom

Nr.: 502.609 00 09 silber

RECHTE SEITE

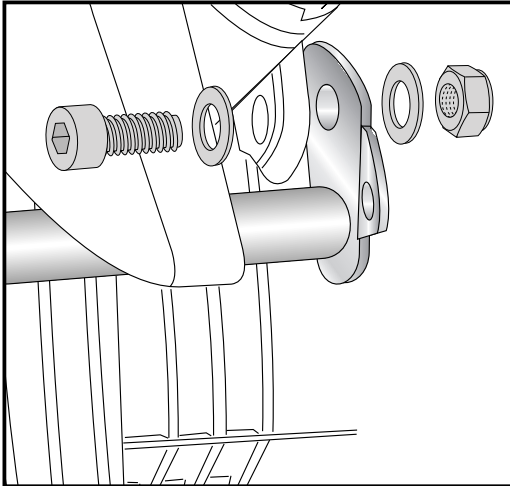

4 Befestigung des Motorschutzbügels oben:
Den Motorschutzbügel so anhalten, dass die obere Befestigungslasche hinter (nach innen gerichtet) der Motorradrahmenlasche anliegt.
Die obere Befestigungslasche mit der Inbusschraube M8x25, den U-Scheiben $\varnothing 8,4$ und einer selbstsichernden Mutter M8 befestigen.

Befestigung des Motorschutzbügels vorne unten :
mit einer Inbusschraube M8x20 und einer U-Scheibe $\varnothing 8,4$. Zwischen dem Motorblock und der Befestigungslasche eine U-Scheibe $\varnothing 8,4$ einfügen.

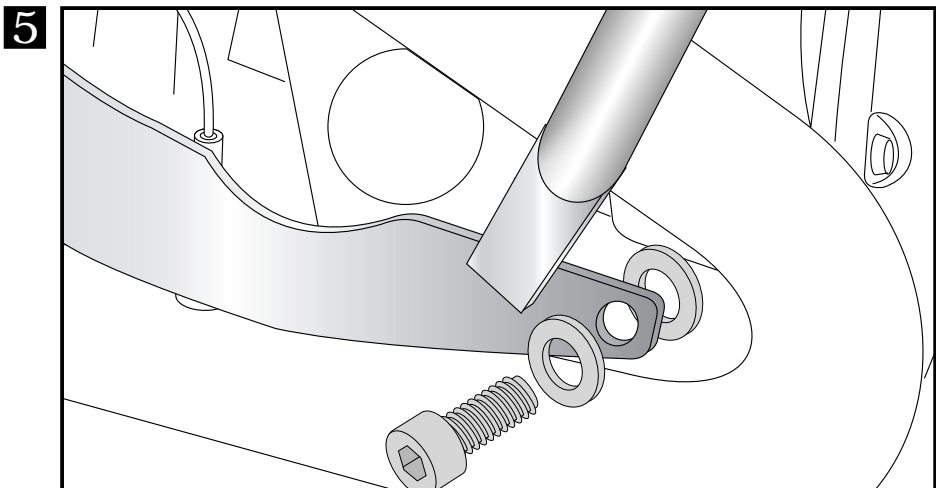

Befestigung des Motorschutzbügels hinten unten:
mit einer Inbusschraube M10x55 und einer U-Scheibe $\varnothing 10,5$. Zwischen Motorradrahmen und Befestigungslasche eine Aludistanz $\varnothing 18 \times 11 \times 13$ einfügen.
Beiden Verkleidungsteile wieder montieren und alle Schrauben fest anziehen!

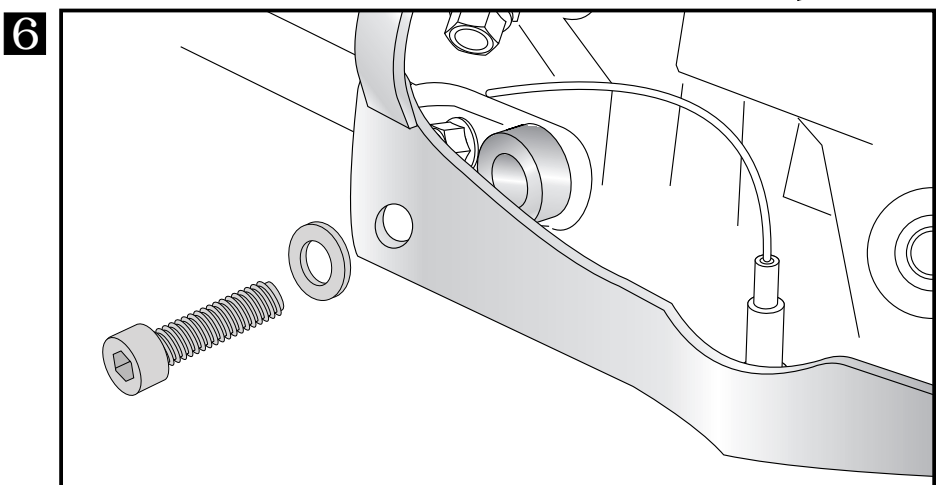

BMW R 1200 RT (from date of manufacture 2014)

powered by

Engine guard

Item-No.: 502.609 00 01 black

Item-No.: 502.609 00 02 chrome

Item-No.: 502.609 00 09 silver

The kit includes the following parts:

Quant	item no.	description	Quant	item no.	description
1	700008441	engine guard, left black	2	150.783	allen screw M8x20 DAC
1	700008442	engine guard, right black	2	150.784	allen screw M8x25 DAC
or			1	150.870	allen screw M10x55 DAC
1	700008443	engine guard, left chrome	8	150.810	washer Ø8,4
1	700008444	engine guard, right chrome	1	150.811	washer Ø 10,5
or			2	150.800	self lock nut M8
1	700008438	engine guard, left silver	1	151.217	alu spacer ø18xø11x13mm
1	700008439	engine guard, right silver			



BMW R 1200 RT (from date of manufacture 2014)
Engine guard

powered by

Item-No.: 502.609 00 01 black
Item-No.: 502.609 00 02 chrome
Item-No.: 502.609 00 09 silver

LEFT SIDE

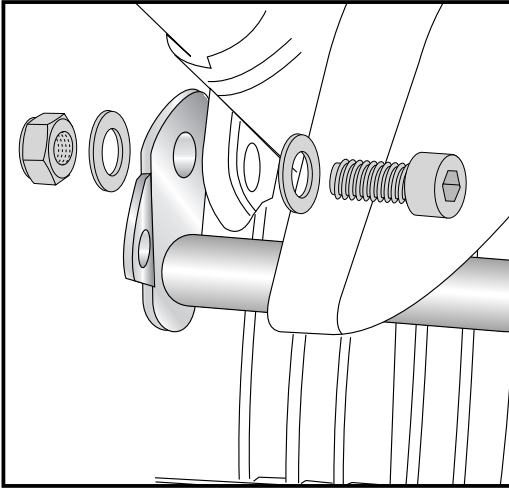

1 **Info:** The assembly of the engine guard should be done one side after the other.

Preparing:

Remove the lower plastic cover around the cylinder on the left and right.

Fastening of the engine guard top:

position the engine guard so that the upper mounting bracket (inward) rests behind the motorcycle frame tab. Fix it with allen screw M8x25 and washer Ø8,4. Secure with washer Ø8,4 and self lock nut M8.

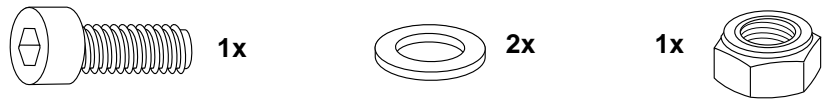

Fastening of the engine guard

front bottom:

use allen screws M8x20 with washers Ø8,4. Sandwich washer Ø8,4 between engine guard and engine block.

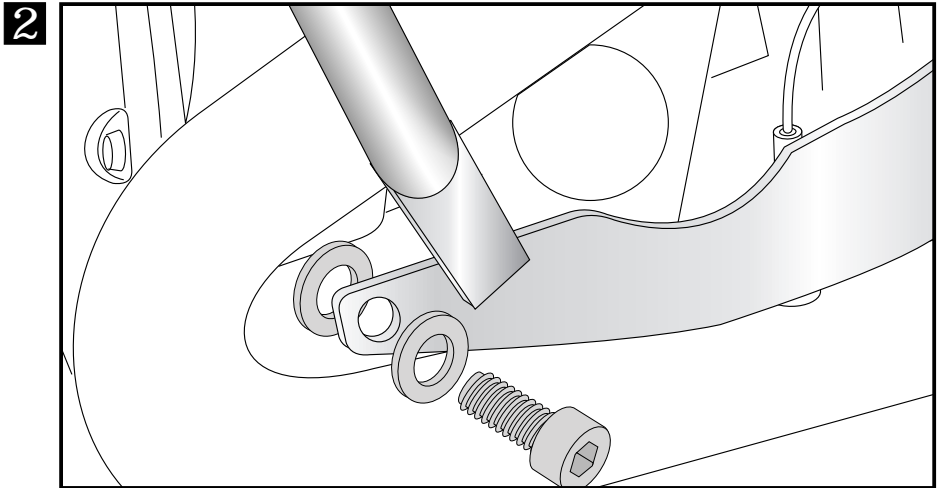
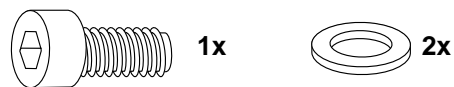

← driving direction

Fastening of the engine guard

rear bottom:

with original screw.

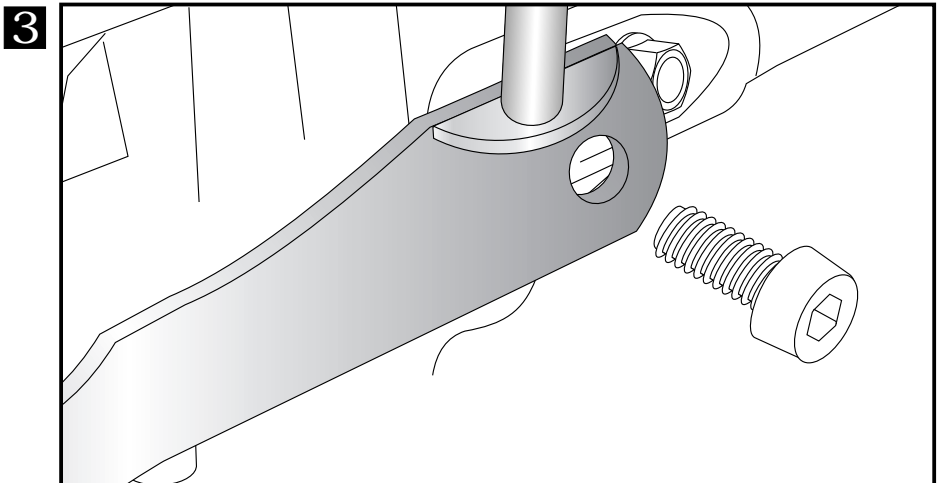



BMW R 1200 RT (from date of manufacture 2014)

powered by

Engine guard

Item-No.: 502.609 00 01 black

Item-No.: 502.609 00 02 chrome

Item-No.: 502.609 00 09 silver

RIGHT SIDE

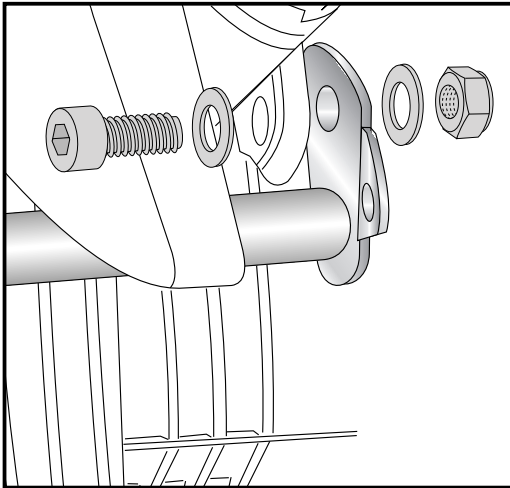

4

Fastening of the engine guard top:
position the engine guard so that the upper mounting bracket (inward) rests behind the motorcycle frame tab. Fix it with allen screw M8x25 and washer Ø8,4. Secure with washer Ø8,4 and self lock nut M8.

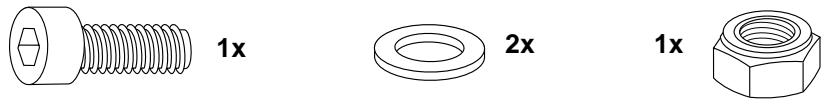

Fastening of the engine guard

front bottom:

use allen screws M8x20 with washers Ø8,4. Sandwich washer Ø8,4 between engine guard and engine block.

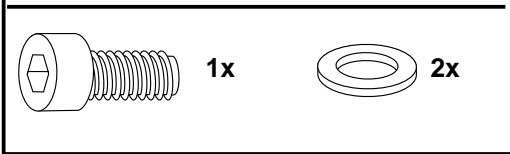

5

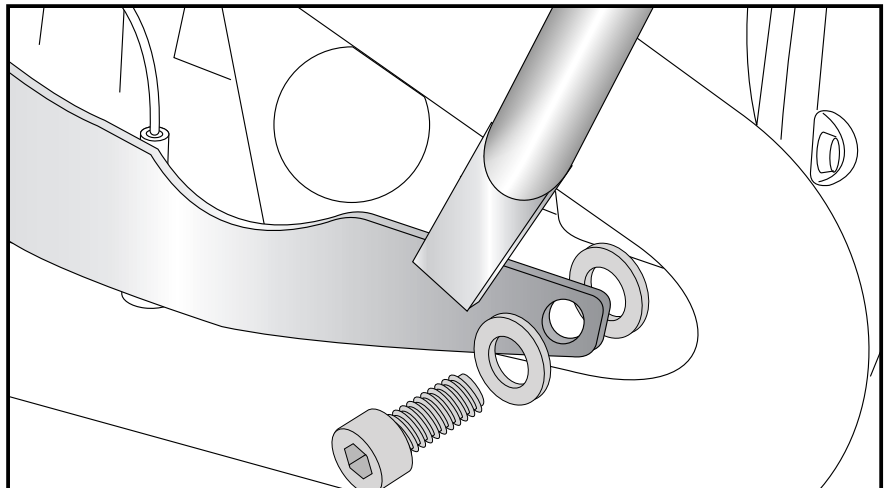

driving direction →

Fastening of the engine guard

rear bottom:

with allen screws M10x55 with washers Ø10,5. Add alu spacer ø18xø11x13 between frame and engine guard.

Fit both covers again and tighten all screws firmly!

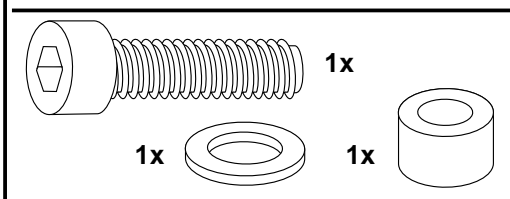

6

