









ANBAUSATZ WERKZEUGBOX

Toolbox mounting set | Kit de fixation boîte à outils | Caja de herramientas del kit de fijación | Kit d'attacco cassetta degli attrezzi

DE Die Farben der Abbildungen dienen nur der Veranschaulichung.
 EN The colors are for illustrating purposes only.
 FR Les couleurs utilisées sont à titre indicatif seulement.

Artikel.-Nr: **41601-50X/60X**

LEGENDE/KEY/FILE LEGENDE

-  **Anbau Tipp**
Fitting tip
Astuce de montage
-  **Achtung**
Attention
Attention
-  **Vergrößerung**
Magnification
Grossissement
-  **Montagepaste**
Fitting lubricant
Lubrifiant de montage
-  **Zusammenbau**
Assembly
Montage
-  **Schraubensicherung**
Thread locking fluid
Freinfilets
-  **Drehmoment**
Torque
Torque
-  **Reiniger**
Cleaner
Nettoyant



BEZEICHNUNG / DESCRIPTION	DIN	ISO	MENGE QUANTITY
1 Halter 1 / Bracket 1			1
2 Halter 2 / Bracket 2			1
3 Hülse / Sleeve DØ 18,0 - dØ 8,5 - h 7,0mm			2
4 Linsenflanschschaube / Lens head screw M8x35	7381	7381	1
5 Linsenflanschschaube / Lens head screw M8x45	7381	7381	1
6 Distanzscheibe / Washer M8			1
7 Linsenschraube / Lens head screw M6x12	7381	7381	4
8 U-Scheibe / Washer M6	125	7089	4
 Zusammenbau Werkzeugbox / Toolbox assembly			1
Schließblech / Strike plate			1
Passscheibe / Adjusting washer DØ 13,5 - h 0,5 mm			1
Linsenflanschschaube / Lens head screw M4x6			1

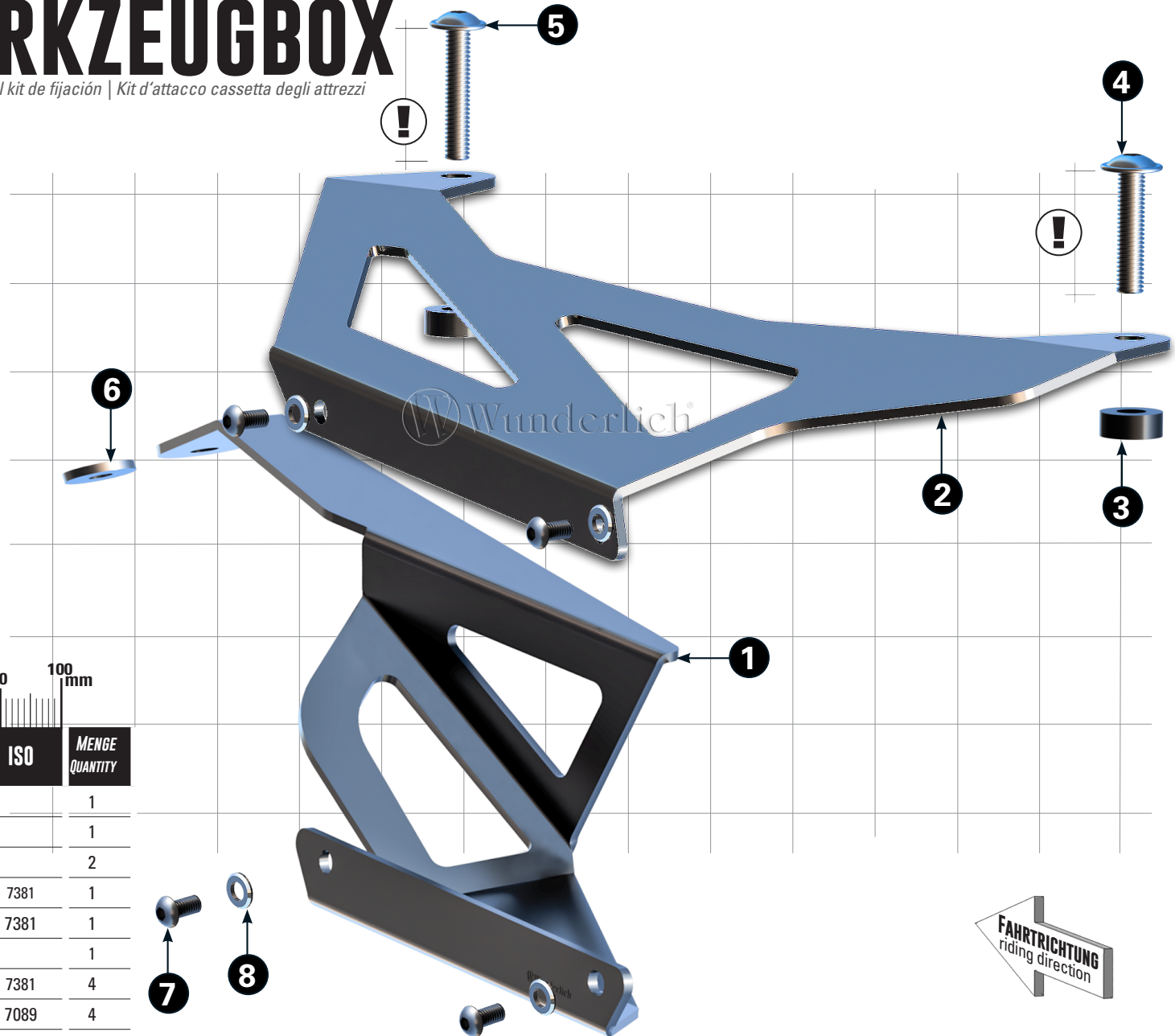



ERST ALLE SCHRAUBEN LOSE EINDREHEN, DANN NACHEINANDER MIT DEM ANGEgebenEM DREHMOMENT FESTZIEHEN !

Loosely pre-assemble all screws and tighten them afterwards.

Pré-assemblez sans serrer tous les raccords à vis et serrez-les ensuite.

3



ERST ALLE SCHRAUBEN LOSE EINDREHEN, DANN NACHEINANDER MIT DEM ANGEgebenEM DREHMOMENT FESTZIEHEN !

Loosely pre-assemble all screws and tighten them afterwards.

Pré-assemblez sans serrer tous les raccords à vis et serrez-les ensuite.

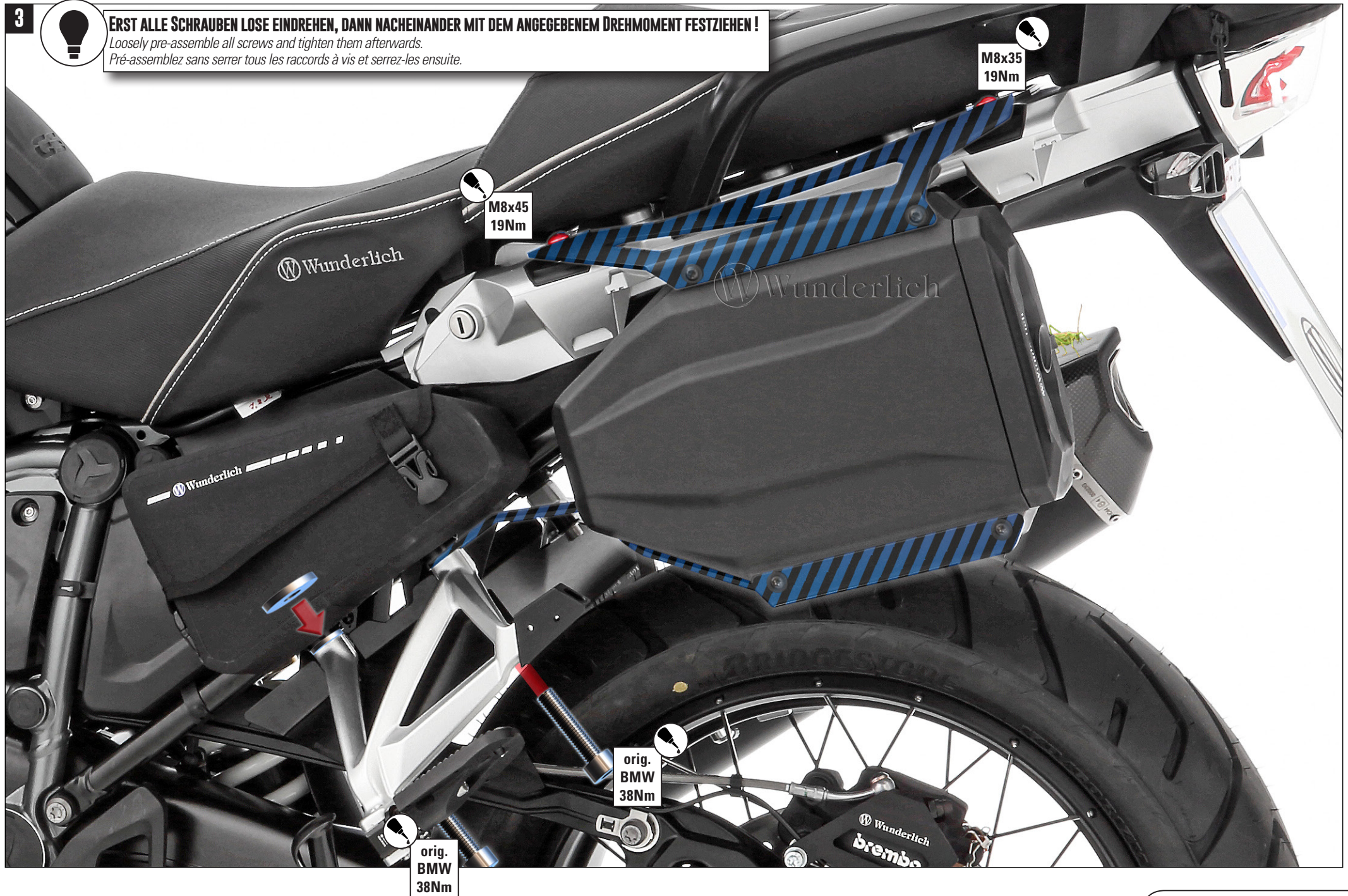

M8x35
19Nm

M8x45
19Nm

orig.
BMW
38Nm

orig.
BMW
38Nm